



PRO307

**DRAFTING AND
DRAWING MANAGEMENT GUIDELINES
FOR CAPITAL PROJECT DELIVERY**

Doc ID:	PRO307	Version:	4	Active date:		
Doc owner:	Glenn Southern			Review date:		
Please note: Printed copies of this document should be verified for currency against online version.						

TABLE OF CONTENTS

1.	DOCUMENT CONTROL	2
1.1	Version Control	2
1.2	Related Documents	2
2.	DOCUMENT PURPOSE.....	3
3.	DRAWING TITLE BLOCK TEMPLATE	3
4.	DRAWING PRESENTATION.....	5
4.1	Cover Page	5
4.2	Plotting	5
4.3	Layer Naming.....	6
4.4	Lines	6
4.5	Text.....	6
4.6	Dimensions and Coordinates	6
4.7	Scales	6
4.8	Sections and Details	7
4.9	New and Existing Works	7
4.10	Survey Information.....	8
4.11	Pipe Detailing	8
5.	CHECKING DRAWINGS.....	8
6.	COMPLETED DRAWINGS	9
6.1	Preliminary Drawings	9
6.2	Pre-Construction DRAWINGS	9
6.3	For Construction Drawings	9
6.4	Hard Copies	10
6.5	Paper Quality	10
6.6	Print Quality	10
6.7	Wet Signed	10
6.8	Amended Drawings.....	10
7.	ELECTRONIC COPY DRAWINGS.....	11
7.1	CAD Drawings.....	11
7.2	Transmitting of AutoCAD DRAWINGS	11
8.	AS CONSTRUCTED DRAWINGS	11
8.1	Superseded Drawings	12
8.2	Voided Drawings	12
8.3	Signing and Amending	12
8.4	Producing	12
9.	MODIFYING EXISTING DRAWINGS	14

Doc ID:	PRO307	Version:	4	Active date:		
Doc owner:	Glenn Southern			Review date:		Page 1 of 15
Please note: Printed copies of this document should be verified for currency against online version.						

1. DOCUMENT CONTROL

1.1 VERSION CONTROL

REVISION	DATE	CHANGE OR ACTION	AMENDED BY
0	Sep 2013	Original	Glenn Southern
1	July 2019	Drafting Guidelines generally revised. Drawing Revision annotation process altered. Drawing Management Guidelines revised to align with the 'Redeye' DMS.	Glenn Southern

1.2 RELATED DOCUMENTS

REFERENCE	DESCRIPTION
PRO395	QUU Addendum to SEQ Water Supply and Sewerage Design & Construction Code (SEQ WS&S D&C Code)
SEQ WS&S D&C Code AIS	SEQ Water Supply & Sewerage Design & Construction Code Asset Information Specification
TMS1654	Naming Requirements for Engineering Documentation

Doc ID:	PRO307	Version:	4	Active date:		
Doc owner:	Glenn Southern		Review date:		Page 2 of 14	
Please note: Printed copies of this document should be verified for currency against online version.						

2. DOCUMENT PURPOSE

The purpose of this document is to describe the Queensland Urban Utilities (QUU) Drafting Guidelines and Drawing Management Practices for Civil, Structural, Mechanical, Electrical, Piping and Instrumentation, Control, Process and Survey drawings.

This document applies to drawings produced by QUU internally, and externally by consultants and contractors engaged by QUU.

This document (PRO307) shall be read in conjunction with, and take precedence over the:

- Australian Standard AS1100.101 - Technical Drawing General Principles
- SEQ Water Supply & Sewerage Design and Construction Code - Example Guide Drawings
- Other Reference Documents noted in Section 1.2 – Related Documents.

This document (PRO307) shall be read in conjunction with:

- TMS1654 – Naming Requirements for Engineering Documentation.

All drawings numbers and drawing title block templates are issued and managed within QUUs RedEye Drawing Management System (DMS).

3. DRAWING TITLE BLOCK TEMPLATE

Drawings for all disciplines shall be produced to A1 sheet size. This includes Civil, Mechanical, Electrical, Piping and Instrumentation, Control, Process and Structural. Survey Drawings for Easement and Land Acquisition Proposal Plans, and Access Agreement Plans shall be produced to A3 sheet size.

Drawing title block templates will be available from the RedEye DMS as a template in 'AutoCAD'.dwg format, and will include QUU approved plot styles, QUU line types, and QUU approved standard blocks. QUU may revise the RedEye version of this title block from time to time. The latest version of the drawing title block template will always be released at the commencement of each new contract with any new drawing numbers. Use of previous drawing title block templates will not be approved if submitted to the DMS.

Revision of any existing drawings shall use the latest QUU drawing title block.

New drawings shall use the latest QUU title block.

For new drawing numbers, a request shall be submitted to QUU as early as possible.

QUU drawing title blocks cannot be exploded nor modified.

All drawing title block fields must be completed prior to formal issuing of each drawing, as detailed below.

Doc ID:	PRO307	Version:	4	Active date:		
Doc owner:	Glenn Southern			Review date:		Page 3 of 14
Please note: Printed copies of this document should be verified for currency against online version.						

3.1.1 ASSET / PROJECT | DRAWING TITLE | DRAWING STATUS | DRAWING NO. | REV TITLE BLOCKS

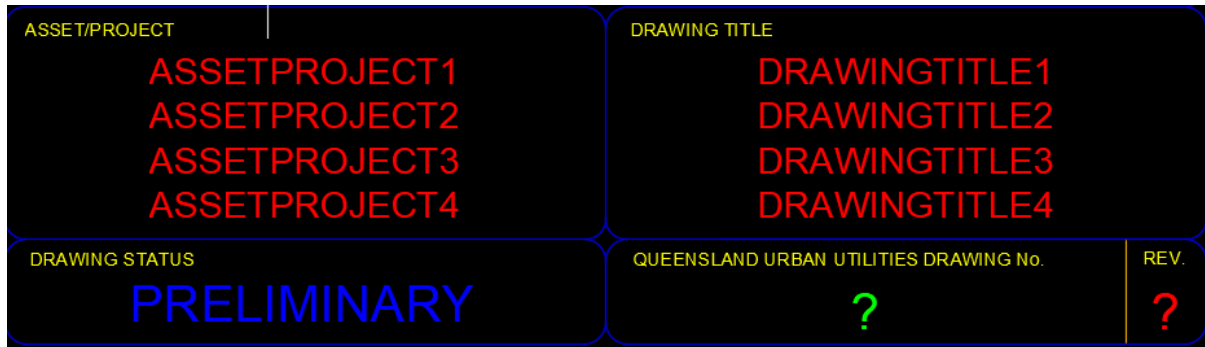

Figure 1-1: Asset/Project, Drawing Title, Drawing Status, Drawing No. and Rev blocks from the QUU drawing title block template

The title block shall be completed as follows:

- ASSETPROJECT 1 – QUU Site Number and QUU Site Name (PRO395 - Appendix B)
- ASSETPROJECT2 – QUU Site Address (PRO395 – Appendix B)
- ASSETPROJECT3 – QUU Sub Process Number and QUU Process Name (PRO395 – Appendix C)
- ASSETPROJECT4 – QUU Project Name.
- DRAWINGTITLE1 – Type of document, e.g. General Arrangement, Single Line Diagram, I/O List, or free text
- DRAWINGTITLE2 – Populate as per drawing text fields, e.g. Plan View, Site Cover Sheet
- DRAWINGTITLE3 – Free text
- DRAWINGTITLE4 – Free text

ASSET/PROJECT	DRAWING TITLE
Example 1	
SP010 EAGLE FARM CPS 5 BUNYA STREET EAGLE FARM 0190 PROCESS, CONTROL & ELECTRICAL PLC REPLACEMENT PROGRAM	TERMINATION DIAGRAM ANALOG INPUTS PLC 11 PUMP 11
Example 2	
ST018 LUGGAGE POINT STP 200 MAIN BEACH ROAD PINKENBA 0230 GRIT REMOVAL CHANNEL REHABILITATION PROJECT	GENERAL ARRANGEMENT PLAN AND ELEVATIONS
Example 3	
ST018 LUGGAGE POINT STP 200 MAIN BEACH ROAD PINKENBA 0840 BIOSCRUBBER PLANT 1 AIR TREATMENT FACILITY UPGRADE	PROCESS & INSTRUMENTATION DIAGRAM EXTRACTION FANS

The Drawing Title fields are free fields to identify document contents, e.g. Reinforcement Details, Piping General Arrangement, Blower No. 1 Single Line Diagram.

Drawing Status is a dynamic block and consists of 'PRELIMINARY', 'CONCEPT', 'FOR TENDER', 'FOR CONSTRUCTION', and 'AS CONSTRUCTED'.

Drawing revision is as per AS1100; new drawings shall be:

- PRE-CONSTRUCTION Alphabetical revision (A to Z)
- FOR CONSTRUCTION Numerical revision, starting at 0 (zero)
- AS CONSTRUCTED Next numerical revision.

3.1.2 DRAWING TITLE

AMENDMENTS						AS CONSTRUCTED CERTIFICATION FOR DRAWING REVISION			ENGINEERING CERTIFICATION			ENGINEERING					
						I CERTIFY THAT THE AS CONSTRUCTED DETAILS SHOWN ON THIS PLAN ARE A TRUE AND ACCURATE RECORD OF THE WORKS.			SIGNATURE			DD.MM.YY					
									RPEQ No.			DISCIPLINE			DATE		
						SIGNATURE			DATE			DESIGNED BY			DATE		
						RPEQ No.			DISCIPLINE			DATE			QUU CIP CODE		
REV. DATE DESCRIPTION DESIGNER SIGNED RPEQ SIGNED RPEQ NO. COMPANY NAME						SIGNATURE			DATE			DESIGN MANAGERS SIGNATURE			DATE		
						NAME			RPEQ No.			DATE			QUU FILE REFERENCE		
						COMPANY NAME			PRINCIPAL CONTRACTOR'S SIGNATURE			DATE			QUU WORK ORDER No.		

For formally issued PRE-CONSTRUCTION drawings, the first revision shall have all sections above completed, except for the 'AS CONSTRUCTED CERTIFICATION' section. For each 'PRE-CONSTRUCTION' revision thereafter, only the amendments section on the left shall be completed: the Engineering and Engineering Certification fields shall remain as per the initial revision, until it reaches 'For Construction'.

For the initial 'FOR CONSTRUCTION' drawing revision, all fields including Engineering, Engineering Certification and Amendments sections shall be cleared, and then the 'FOR CONSTRUCTION' drawing revision details shall be completed for all sections, excepting the 'AS CONSTRUCTED CERTIFICATION' section. For any subsequent 'FOR CONSTRUCTION' revision, the Engineering and Engineering Certification sections shall be updated to reflect the latest revision.

For the 'AS CONSTRUCTED' drawing revision, the Engineering and Engineering Certification shall retain the For Construction history. The 'AS CONSTRUCTED CERTIFICATION' details MUST be filled in, in addition to the Amendments fields. All For Construction revision history shall be retained in the Amendments field.

Other field entries are as follows:

- QUU CIP Code – these reference the QUU project number, e.g. BWWTAA29
- QUU File Reference – this is a QUU provided number from QDox, e.g. P18/359
- QUU Work Order No – unless provided by QUU, enter N/A e.g. PB012345.

4. DRAWING PRESENTATION

4.1 COVER PAGE

QUU requires each package of work to be accompanied by a Cover page including Locality Plan, Drawing Index and notes. This shall include Abbreviations and legend utilised throughout the drawing set.

4.2 PLOTTING

Details such as drawing sheet size, line thickness and text requirements are imposed to provide

Doc ID:	PRO307	Version:	4	Active date:		
Doc owner:	Glenn Southern	Review date:				Page 5 of 14
Please note: Printed copies of this document should be verified for currency against online version.						

drawings suitable for scanning to Adobe Acrobat .pdf format files at A3 size and in Landscape orientation These shall be created using Autodesk’s internal DWG to PDF conversion and retain layer information on the pdf output.

4.3 LAYER NAMING

For Civil, Mechanical and Survey drawings, QUU has no standard for layer name convention, dim style, etc, however it is expected the layers and line types are consistent across all drawings in a project, and layer naming be self-explanatory.

In addition to the above, Electrical drawings shall be drawn to AS3000 standards.

Process drawings and symbols shall be drawn utilising ISA standards, reverting to ISO standards to fill in any gaps.

4.4 LINES

When selecting a line thickness, it must be considered that the drawings will be reproduced at a smaller size such as A1 to A3, so the minimum line thickness is to be 0.25mm. The line thicknesses to be used are: 0.25 mm, 0.35 mm, 0.50 mm, 0.70 mm, 1.00 mm, 2.00 mm, 3.00 mm and so on.

Effective drawing layer management is a QUU requirement. Layer manager helps to control line colours, styles, visibility, and plotting:

- Objects shall not be drawn on 0 (zero) layer – except contents of drawing blocks
- No forced colour and line type changes are permitted.

Line styles to be used are set out in AS1100.101 Table 3.1, and any additional styles provided by QUU.

The embedded text in user defined lines is to be Arial Font and have a minimum height of 2.5 mm.

4.5 TEXT

AS1100.101 Table 4.1 details the recommended text heights.

Text font should be to AS1100.101, Arial Text. All text is to be in upper case including all annotation, notes and titles, except where naming convention requires otherwise, ie. mm, kPa.

Text shall not be overwritten with lines or other drawing entities.

4.6 DIMENSIONS AND COORDINATES

No dimensions and coordinates are to be overwritten.

4.7 SCALES

As the drawings may be reproduced at half scale, it is necessary to choose a scale that when doubled in size is still a common scale available. The scales on A1 or A3 sheets shall be: 1:1, 1:2, 1:5, 1:10, 1:20, 1:25, 1:50, 1:100, 1:250, 1:500, 1:1000, 1:2500, 1:5000, 1:10000.

All drawings must have a scale bar showing the predominate scale.

Process drawings shall be drawn at 1:1 scale. Electrical drawings that are not General Arrangement style (e.g. single line diagrams, schematics, termination drawings, loop diagrams, cable block diagrams) runs must be drawn at 1:1 scale.

Drawing of all data in model space shall be at 1:1 scale.

Doc ID:	PRO307	Version:	4	Active date:		
Doc owner:	Glenn Southern			Review date:		Page 6 of 14
Please note: Printed copies of this document should be verified for currency against online version.						

4.8 SECTIONS AND DETAILS

Section and Detail indicators shall be to AS1100.101, Figure 7.3 Sheets 1 and 2, except that Section indicators are to be annotated with an Alpha character for the section, and the last three digits of the drawing number on which the section appears.

Detail indicators are to be annotated with a Numeric character for the detail, and the last three digits of the drawing number on which the detail appears.

If the indicator and the section are on the one drawing, then the drawing digits shall be substituted with a dash. Figures 1 and 2 show typical annotations.

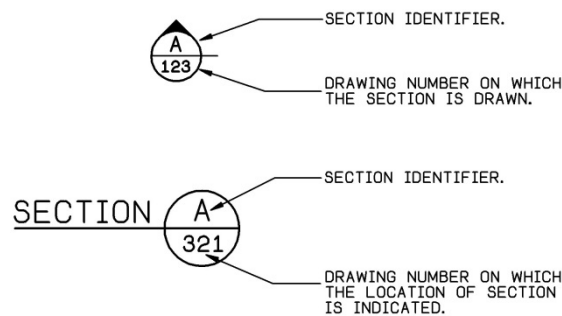

Figure 1

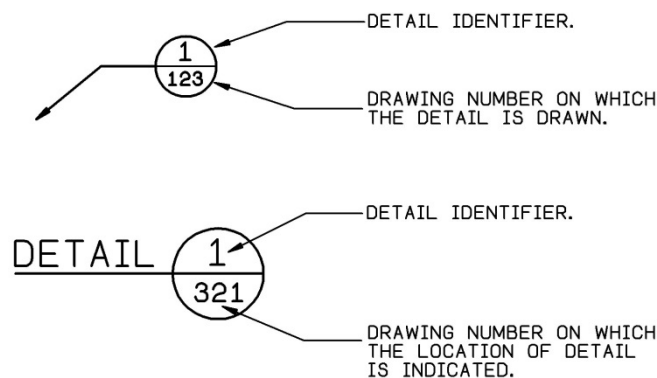

Figure 2

On civil, structural and mechanical drawings (such as within pumping stations and treatment plants), a graphical representation of a person at correct height is to be included on all sections.

4.9 NEW AND EXISTING WORKS

New and existing works are to be distinguished using either line thickening and/or shading. **Figures 4 and 5** shown below illustrate these alternatives.

Colour may be applied to drawings, rather than being restricted by black and white. This will assist in identifying new / proposed works against busy existing workings, and open the realm of layering on a drawing. Refer 4.1 COVER PAGE for Legend requirements.

Doc ID:	PRO307	Version:	4	Active date:		
Doc owner:	Glenn Southern			Review date:		Page 7 of 14
Please note: Printed copies of this document should be verified for currency against online version.						

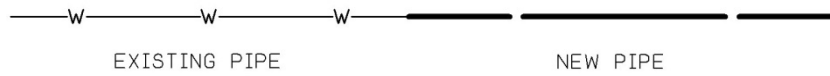

Figure 4

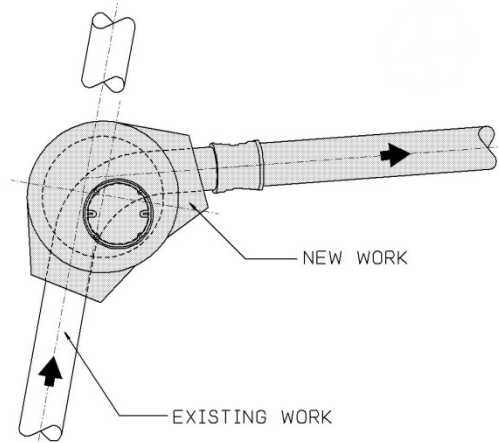

Figure 5

4.10 SURVEY INFORMATION

The levels and coordinates are to be shown in metres to three decimal places. Datum is to be AHD MGA94.

In drawings that contain property boundaries, offset dimensions from these boundaries to new works are to be shown. These offsets are to be shown on all drawings, where practical, even if the coordinates are provided.

Supplied survey information and drawing data shall be in GDA94 / MGA 56 spatial reference.

4.11 PIPE DETAILING

All new pipes are to be clearly marked with the diameter of the pipe, material, and class. The following is an example of a 100mm diameter polyethylene pipe (e.g. DN125 PE100 SDR11 PN16).

All existing pipes shall be clearly marked with the diameter and material as a minimum.

All pipes over 355mm in diameter and all pipes that are manufactured to order, such as mild steel cement lined pipes, are to have a pipe dimension tabulation included in the project drawings. This tabulation shall include pipe material, outside diameter, wall thickness, internal lining thickness, internal diameter, pressure rating or class and external coating.

Arrows shall be shown to indicate all pipe flow directions for sewers.

5. CHECKING DRAWINGS

All drawings are to have a Drafting Check in accordance with AS1100.101, the requirements of this document, and any additional checks as required by Queensland Urban Utilities. The Drafting Checkers' details are not required on the title block. Rather, if QUU request, details of a Drafting Check must be submitted electronically.

Doc ID:	PRO307	Version:	4	Active date:		
Doc owner:	Glenn Southern	Review date:				Page 8 of 14
Please note: Printed copies of this document should be verified for currency against online version.						

6. COMPLETED DRAWINGS

All drawings at all phases of design and implementation must have the amendment status included with the drawing number.

The below table indicates drawings required for various stages of project deliverables, to be issued to QUU.

The AutoCAD dwg formats submitted to QUU will typically be uploaded by QUU Document Control, and will be loaded onto QUU's RedEye DMS.

	AutoCAD dwg format	PDF Output	Wet Signed PDF
Preliminary	No	Yes	No
Market Ready Design	Yes	No	Yes
FOR CONSTRUCTION stages	Yes	No	Yes
AS CONSTRUCTED	Yes	No	Yes

6.1 PRELIMINARY DRAWINGS

For Preliminary drawings, the Revision number shall be alphabetical and commence at the letter 'A', followed by 'B', 'C', etc.

Preliminary drawings are not to be issued to a constructor without prior consent from the Project Manager. If consent is given, then a stamp or watermark is to be prominently placed on the drawing and shall be inscribed 'NOT FOR CONSTRUCTION – FOR INFORMATION ONLY'. In addition, the drawing status shall remain as Preliminary.

For all other types of issue, the drawing MUST be fully signed. Preliminary AutoCAD dwg format drawings are not required to be uploaded to RedEye DMS until further notice.

For modification to existing drawings, refer to Section 9 Modifying Existing Drawings.

6.2 PRE-CONSTRUCTION DRAWINGS

For "PRE-CONSTRUCTION" drawings, appropriately signed and accepted by QUU, that are required to be issued shall have the Amendment Status updated from the preliminary amendment letter, to the next Alphabetical revision. The reason for the issue is as per Section 3.1.1 Asset / Project, which utilises the 5mm high text dynamic block, in the title block's DRAWING STATUS area.

The reason for issue may include FOR INFORMATION, FOR QUOTATION, FOR TENDER.

For modification to existing drawings, refer to Section 9 Modifying Existing Drawings.

6.3 FOR CONSTRUCTION DRAWINGS

For "FOR CONSTRUCTION" drawings, appropriately signed and accepted by QUU, that are required to be issued shall have the Amendment Status updated from the previous amendment, to '0' (zero). The reason for the issue is as per Section 3.1.1 Asset / Project, which utilises the 5mm high text dynamic block, in the title block's DRAWING STATUS area.

All Amendment History is to be deleted and reflect the current FOR CONSTRUCTION description.

When the drawing is completed, checked and is ready for issue, then it must be signed. A hard copy is to be produced, and all signatory boxes are to be completed with wet signatures. Please refer to

Doc ID:	PRO307	Version:	4	Active date:		
Doc owner:	Glenn Southern			Review date:		Page 9 of 14
Please note: Printed copies of this document should be verified for currency against online version.						

Section 6.4 Hard Copies.

The reason for issued will be “FOR CONSTRUCTION”.

Any additional “FOR CONSTRUCTION” drawing revisions shall be as per Section 6.8 Amended Drawings.

Refer to Section 6.7 Wet Signed for wet signature requirements.

For modification to existing drawings, refer to Section 9 Modifying Existing Drawings.

6.4 HARD COPIES

QUU do not require hard copies for any submission. The following applies for printing of drawings for Wet Signature only.

6.4.1 SCALING

The hard copy prints for wet signature must be scaled correctly. Drawings printed to ‘Fit to Page’ are not acceptable.

6.4.2 PAPER SIZE

The current supplied QUU title block is A1 size, to allow the bigger drawing space. Printing must be to A3, as per Section 4.2 Plotting requirements.

6.5 PAPER QUALITY

Paper quality is to be a minimum of 80 GSM Bond Plot Paper.

Original wet signed drawings are not to be folded.

6.6 PRINT QUALITY

Printing quality is to be High Quality with 100% screening. (Not Draft Quality).

6.7 WET SIGNED

Immediately following the signing of the hard copy, the signatory’s names, date of signing and (where applicable) their RPEQ number is to be added to the title block on the CAD file, along with the words “ORIGINAL SIGNED”.

A 400DPI A3 size .pdf file is to be produced from this updated CAD file. The .pdf file name must include the drawing number in full and the amendment letter (example 562003123_0.pdf). The .pdf shall be landscape orientated, as per Section 4.2 Plotting.

The amendment letter on the CAD file is to remain the same as the wet signed hard copy drawings, e.g. ‘0’.

Presence of the RPEQ number of the Designer or Design Checker is mandatory for all original wet signed drawings being issued (except survey plans). It must also appear on the .pdf.

Scanned wet signed hard copy drawings, .dwg files and .pdfs are to be issued with a transmittal document to Queensland Urban Utilities, as per Section 6 Completed Drawings requirements.

Wet signed hard copies are to be retained by the contractor and are not transmitted to QUU.

6.8 AMENDED DRAWINGS

If a drawing requires amending after the original issue ‘0’, then the Revision Box near the drawing number is to be updated with the next number e.g. ‘1’, ‘2’, etc. In addition, the amendment tabulation box on the bottom left of the drawing is to be populated and include a brief outline of the

Doc ID:	PRO307	Version:	4	Active date:		
Doc owner:	Glenn Southern			Review date:		Page 10 of 14
Please note: Printed copies of this document should be verified for currency against online version.						

amendment. The initials of the designer, plus the wet signature of the certifying RPEQ, their RPEQ number and their discipline, are to be included.

The amended portion of the drawing is to be surrounded with a cloud and an amendment marker attached. The cloud is to be formed with a 0.25 thick line and the marker is to be a 3.5 high letter surrounded with a triangle. If there is more than one area of the drawing amended then a cloud and the same lettered marker is to be placed over each section. Figure 6 below illustrates this.

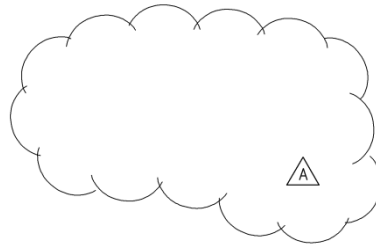

Figure 6

If subsequent amendments are made to the drawing, the previous amendment cloud is to be removed from its existing location, a new cloud placed around the new amendment and a new marker triangle added. The marker triangle located near the previous amendment is to remain on the drawing, and greyed out to help maintain drawing clarity.

7. ELECTRONIC COPY DRAWINGS

7.1 CAD DRAWINGS

The name of the electronic drawing file shall be the drawing number. The file name is to be recorded on the title block of each drawing and is to include the RedEye artefact number (if present) and file extension. For example: 562003123_0.dwg

Generally there should be a separate file for each individual drawing. Only the Senior Technical Officer of Queensland Urban Utilities may approve the saving of multi file format (several drawings combined under the one file name).

External reference drawings may be used during the production of a single drawing only. On completion of the drawing, the drawing file shall be cleaned up with all non-used information removed. In addition the files must have all XRef's bound and purged.

The hard copy prints must be able to be scaled correctly. Drawings printed to "Fit to Page" are not acceptable.

7.2 TRANSMITTING OF AUTOCAD DRAWINGS

All AutoCAD dwg files transmitted to QUU shall be bound together, via the AutoCAD e-transmit function. The bound type needs to be 'INSERT', as this will not modify the layer naming of the file to be bound. All drawings must be able to standalone and be able to be moved or copied to other directories or emailed without loss of data.

AutoCAD files shall be provided to Queensland Urban Utilities in Version 2017 format, unless written authorisation has been provided by Senior Technical Officer of Queensland Urban Utilities.

8. AS CONSTRUCTED DRAWINGS

'As Constructed' drawings are to be produced for all projects and must accurately reflect all the

Doc ID:	PRO307	Version:	4	Active date:		
Doc owner:	Glenn Southern			Review date:		Page 11 of 14
Please note: Printed copies of this document should be verified for currency against online version.						

works built.

If a sketch is used to assist during construction, the contents must be moved to a drawing that will be “AS CONSTRUCTED”, and the sketch must be updated with a SUPERSEDED stamp (refer description below). The Amendments description shall identify SKETCH SUPERSEDED BY XXXXXXXXXXXX (new drawing number), dated, and digitally initialled by the DESIGNER in AutoCAD only.

8.1 SUPERSEDED DRAWINGS

SUPERSEDED stamped drawings are where the contents are no longer valid. If SUPERSEDED, the drawing must be updated with a SUPERSEDED stamp. Where the contents have been added to an “AS CONSTRUCTED” drawing, the Amendments Description shall identify DRAWING SUPERSEDED BY XXXXXXXXXXXX (new drawing number), dated, and digitally initialled by the DESIGNER in AutoCAD only. SUPERSEDED drawing number can be bought back to life at any time, but they must retain the same drawing title.

8.2 VOIDED DRAWINGS

VOIDED stamped drawings are where the contents are irrelevant to the project deliverable, and this drawing cannot be returned to life. This drawing shall be updated with VOIDED stamp on the drawing. The Amendments description shall identify DRAWING VOIDED, dated, and digitally initialled by the DESIGNER in AutoCAD only.

8.3 SIGNING AND AMENDING

“AS CONSTRUCTED” drawings are to be updated with a new Amendment number, and the Amendment tabulation is to be updated to read “AS CONSTRUCTED”. The approver’s initials should be of the person who checked the drawing.

In addition, the ‘As Constructed Details’ box in the border above the drawing number is to be completed. In all civil and mechanical works the drawing MUST be signed by a Registered Professional Engineer of Queensland or Electrical Contractors License for electrical drawings. The wet signature pdf drawings are to be electronically submitted to QUU for acceptance.

All revision clouds and triangles for the first “As Constructed” revision are to be deleted from the drawing. Any subsequent revisions to “AS CONSTRUCTED” drawings need to follow Section 6.8 AMENDED DRAWINGS.

8.4 PRODUCING

There are two acceptable methods for production of “AS CONSTRUCTED” drawings. In both methods the final requirement is a:

- correctly scaled A3 size hard copy drawing containing ‘wet signature/s’ of the RPEQ certifying the drawings,
- an AutoCAD dwg format, as per Section 7 Electronic Copy Drawings.

Method 1

This method involves marking up the existing drawing by clearly defining the altered work. Three examples are given below. The “AS CONSTRUCTED” work is to be shown in the colour red with the incorrect entity crossed out. For this method, all non “AS CONSTRUCTED” data will need to be shown in black / grey scale. A contrasting text font shall be used. These drawings may be marked up by hand on a hard copy drawing or a colour print of an altered CAD drawing produced.

Samples are shown below in **Figures 7, 8 and 9**.

Doc ID:	PRO307	Version:	4	Active date:		
Doc owner:	Glenn Southern			Review date:		Page 12 of 14
Please note: Printed copies of this document should be verified for currency against online version.						

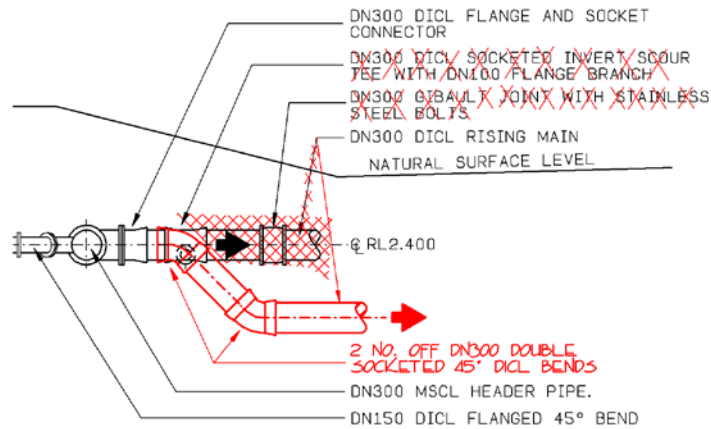

Figure 7 Sample of the “AS CONSTRUCTED” Altered Works

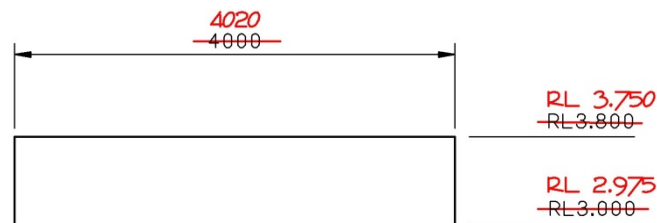

Figure 8 Sample of the “AS CONSTRUCTED” Altered Dimensions and Levels

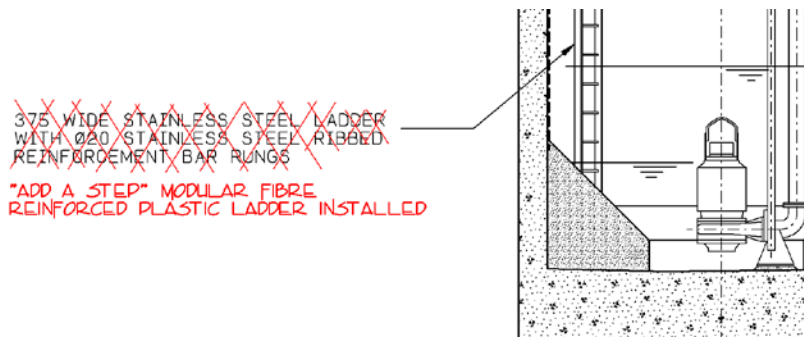

Figure 9 Sample of the “AS CONSTRUCTED” Substituted Works

Method 2

This method involves redrawing the electronic CAD drawing to reflect the final work. The drawing is to have all works not built removed from the drawing and where the structure varied in size and height from the design, the drawing is to be modified to show the revised size and shape. The drawing must be altered and not just the dimension or annotation changed.

If substitute materials such as a different pipe joint type are used, then the drawing is to show the correct materials and in the example of the pipe joint the new pipe joint is to be drawn. This drawing must be able to be scaled and accurately reflect the work as it was constructed.

As the whole of the drawing is “AS CONSTRUCTED”, no red mark-up will appear.

Doc ID:	PRO307	Version:	4	Active date:		
Doc owner:	Glenn Southern	Review date:				Page 13 of 14
Please note: Printed copies of this document should be verified for currency against online version.						

9. MODIFYING EXISTING DRAWINGS

At times, existing drawings will require modifications to reflect the current asset's data. When modifying existing drawing numbers, the drafter shall maintain the existing drawing number, and the revision shall reflect the next character in the sequence, i.e. D, E, F, etc, OR 12, 13, 14, etc.

If there's a new QUU title block, it shall replace the existing data, and the fields are to be updated to reflect the existing. Any unknown non-matching fields are to be confirmed with the Project Manager.

As per Section 6.8 AMENDED DRAWINGS, revision clouds and triangles shall reflect the new additions. Any existing triangles are to be greyed out. Regardless if the existing drawing is "**AS CONSTRUCTED**", and the proposed works is "PRELIMINARY", revision triangles are still required. If this "PRELIMINARY" change becomes "FOR CONSTRUCTION", the previous revision clouds and triangles shall be deleted. The revision history will remain.

Doc ID:	PRO307	Version:	4	Active date:		
Doc owner:	Glenn Southern			Review date:		Page 14 of 14
Please note: Printed copies of this document should be verified for currency against online version.						